



ASSEMBLY INSTRUCTIONS (ON)  
**MODEL NO. 1064320**

Made in China

Thank you for purchasing this CR product. We want to make sure it is complete and to your satisfaction. Please check all packing material carefully for small parts which may have come loose inside the carton during shipment. Hardware can be identified by bright red packaging. Separate, identify, and count all parts and hardware to make sure they match with the illustrations herein and are all present. If any part(s) are missing or defective please contact CR Customer Service. Contact information is given at the bottom of these instructions. If you feel the item is defective beyond a resolution with part replacements, please return this product with your receipt to the place of purchase. If purchased from an internet retailer, please contact their customer service department. Photo's and additional information may be requested to validate the claim. Product is not to be returned to the CR Company under any circumstance unless authorized by the CR Company or an authorized dealer or representative. Thank you.

**ATTENTION: SOME LETTERED PARTS LISTED ON THE INSTRUCTION SHEET MAY NOT BE IN PARTS BAG AS THEY MAY ALREADY BE ASSEMBLED. CAREFULLY CHECK PARTS AND PACKING MATERIALS PRIOR TO ORDERING REPLACEMENTS. REMOVE THE PACKING TAPE FROM THE MIRROR OF THE JEWELRY ARMOIRE TOP. RESIDUAL GLUE CAN BE REMOVED USING PRODUCTS SUCH AS GOO GONE™ OR WD40™, IF NEEDED.**

Tools required for assembly: Phillips Screwdriver (not included)

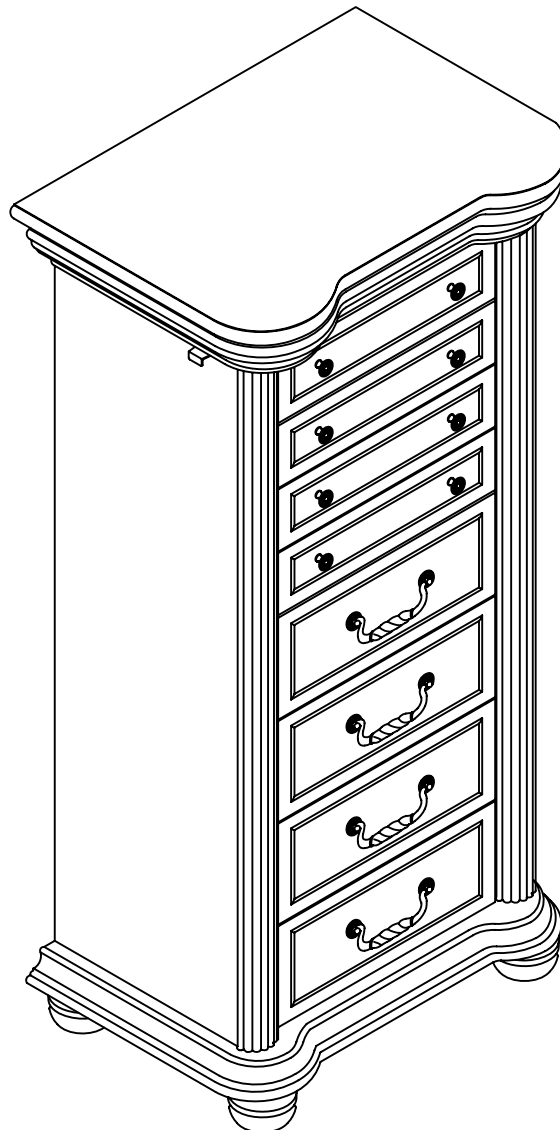

# PARTS

- (A) ARMOIRE(1PC)
- (B) TOP(1PC)
- (C) FEET(4PCS)
- (D) MAMBO BELT(1PC)

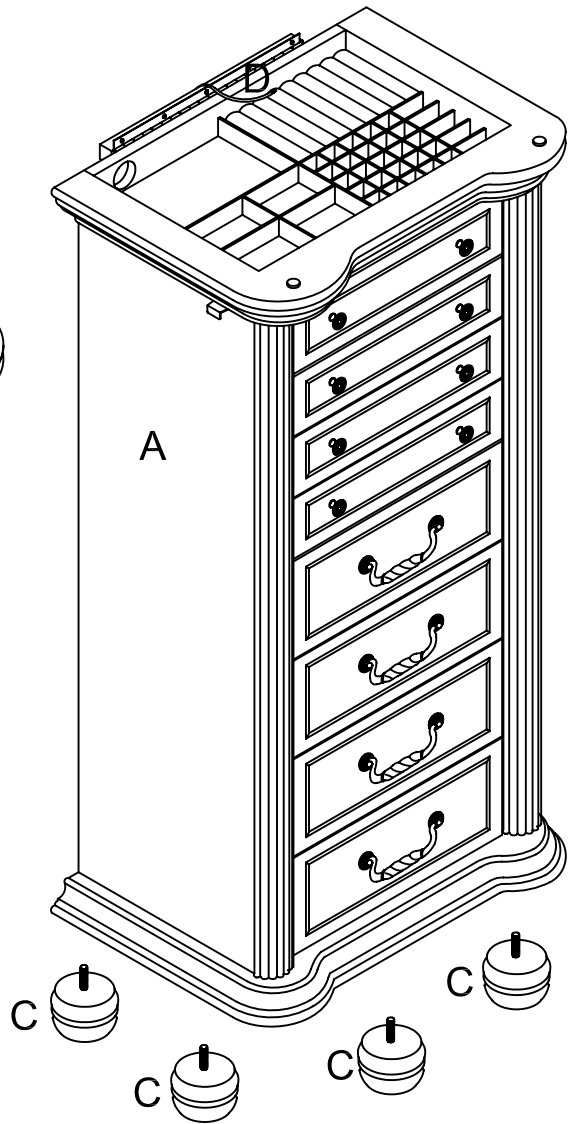
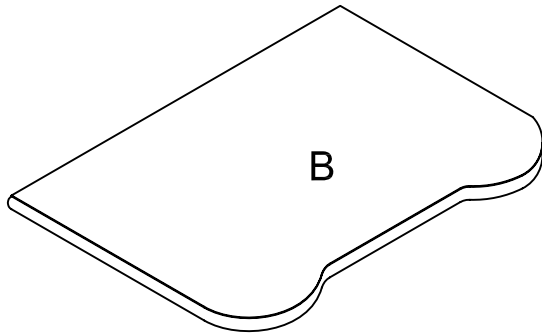

# HARDWARE

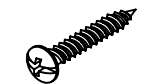

E  
(5 PCS)



F  
(1 PC)



G  
(2 PCS)



H  
(1 PC)



I  
(1 PC)

STEP 1

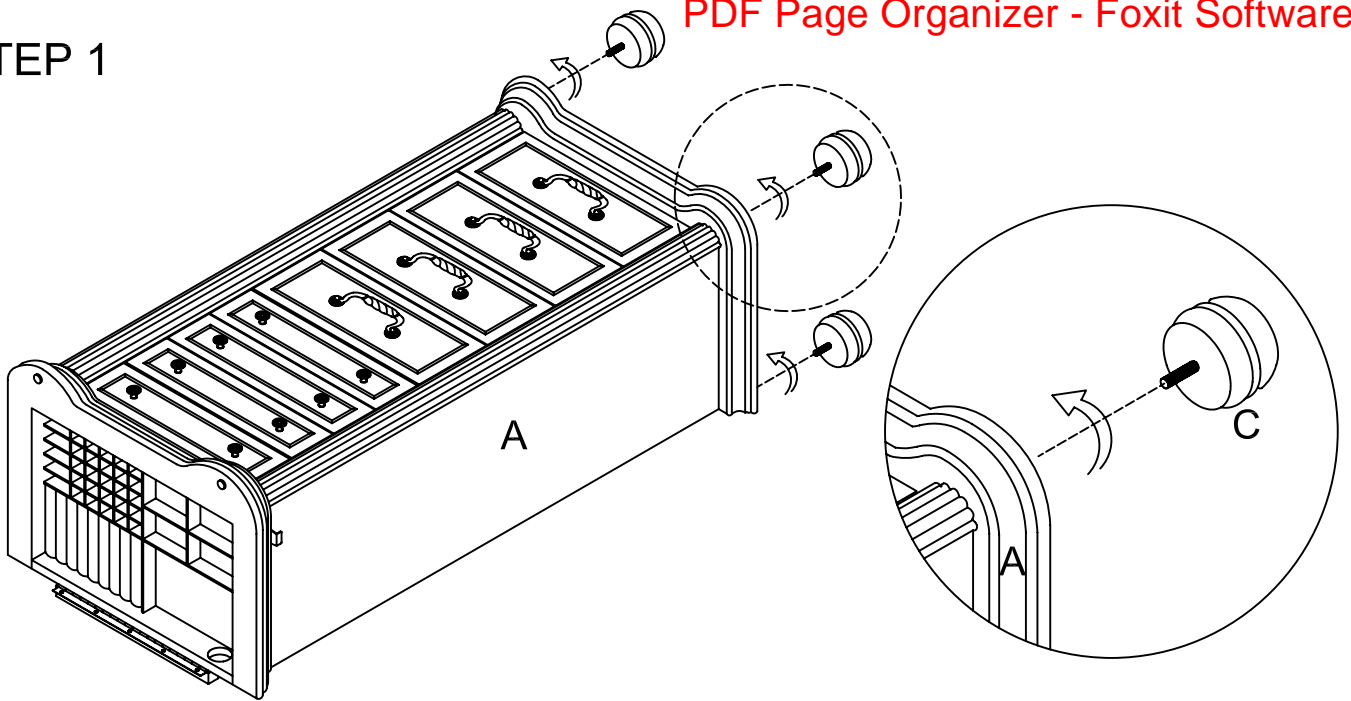

STEP 2

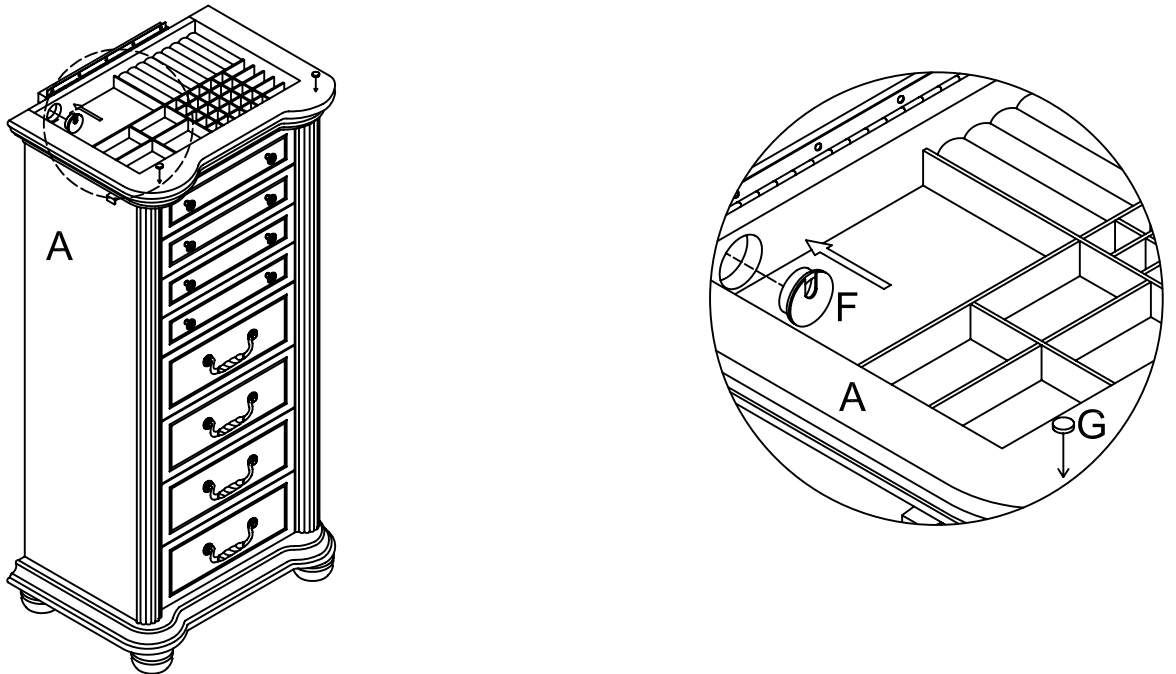

STEP 3

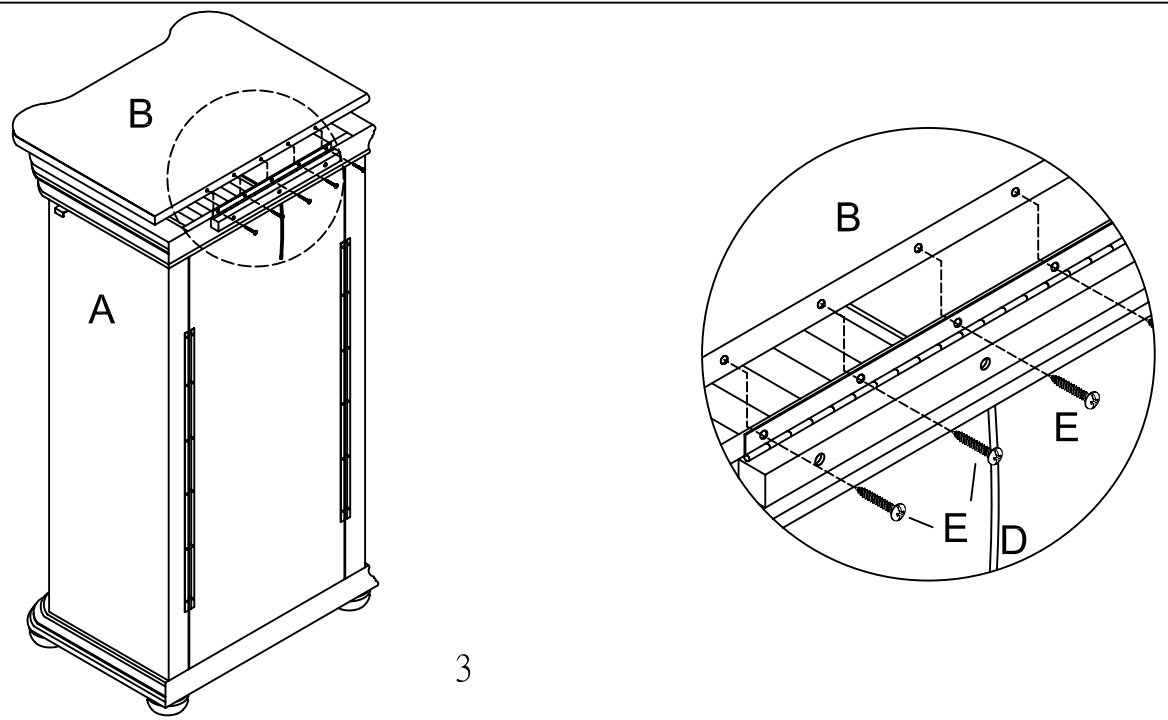

**STEP 4**

**NOTATION: TAKE ASSEMBLED CORD FROM BACK OF CASE AND ATTACH LOOP WITH SCREW INTO WALL ANCHOR.**

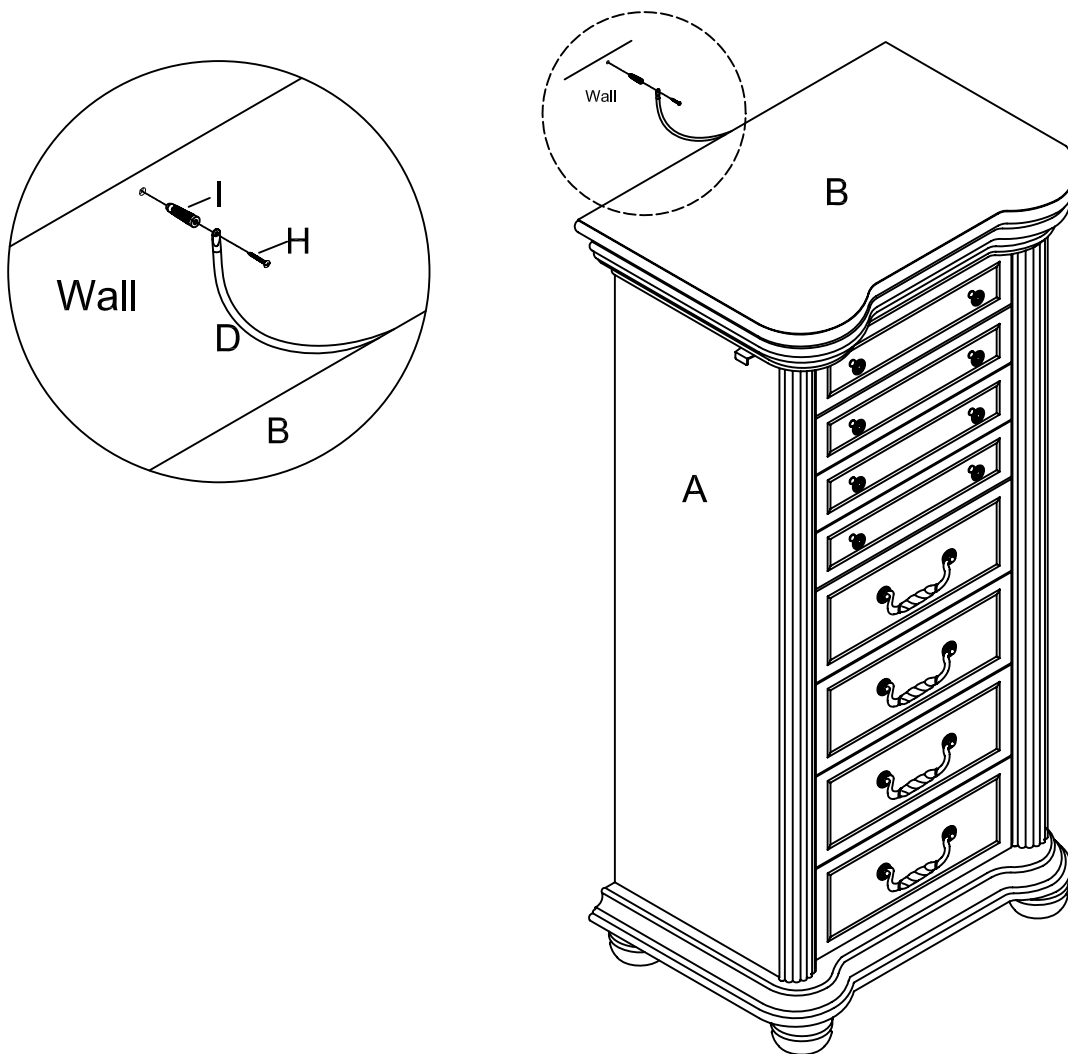

**MODEL NO. 1064320**  
Jewelry Chest

Should there be any missing or defective part(S), **place your part order on line at [criparts@chromrev.com](mailto:criparts@chromrev.com)**, or fax this form to (765) 564-3722, or call Customer Service at (765) 564-2586 extension 277. email parts: [criparts@chromrev.com](mailto:criparts@chromrev.com)

PLEASE HAVE THE MODEL NUMBER, PART CODE AND FACTORY CODE IDENTIFIED.

Part Letter _____	Quantity _____	Name _____
_____		Address _____
_____		City _____ State ____ Zip _____
Reason for replacement _____		(No Post Office Box Addresses)
_____		Best contact phone number ( ____ ) _____
Place of purchase _____		Email address _____
Date of purchase _____		Factory Code(ON) _____